

24" Series 9 Contemporary Compact Convection-Speed Oven

Series 9 | Contemporary



The speed of microwave cooking with the versatility of convection oven technology in a compact companion model, for perfect pairing.

- Generous 1.7 cu ft capacity, with four shelf positions
- A Wired Temperature Sensor precisely monitors cooking in real time
- Guided touchscreen cooking makes it simple to navigate cooking processes

- Wi-Fi enabled and works with the SmartHQ™ app for remote control and notifications

DIMENSIONS

Height	18 "
Width	23 7/16 "
Depth	22 1/4 "

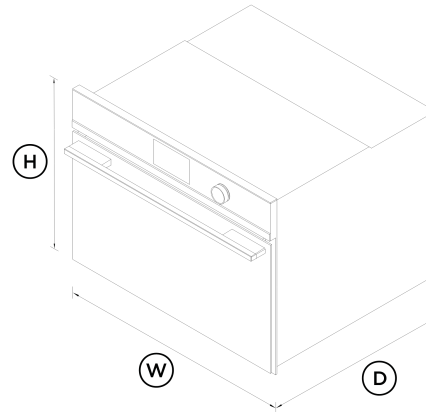

FEATURES & BENEFITS

Cooking Flexibility

Choose from 22 functions, including four microwave-only functions, 14 traditional oven functions, and four combination functions, giving you the best microwave and convection oven technology.

Cook With Confidence

The 5" screen provides an intuitive guided cooking experience that helps to deliver perfect results, whether you've been cooking all your life or are just starting out.

Sized To Suit

A compact 24" width means this microwave oven can be placed almost anywhere – all companion products can be installed at a convenient height to suit your kitchen design and preference.

Complementary Design

Finished in stylish stainless steel with a polished metal trim, our Contemporary style ovens help you to create a coherent, distinctive aesthetic in your kitchen.

Multi-Function Flexibility

Each function has been tailored and tested to ensure perfect defrosting, heating and cooking.

Safe And Sound

The CoolTouch door is safe to touch from the outside, protecting your hands and the surrounding cabinetry.

SPECIFICATIONS

Accessories (included)

Chromed shelf runners	•
Glass tray	1
Step down wire shelf	1
Wire shelf	1
Wired temperature sensor	1

Capacity

Shelf positions	4
Total capacity	1.7 cu ft

<p>Usable capacity 1.3 cu ft</p> <hr/> <p>Cleaning</p> <ul style="list-style-type: none"> Acid resistant graphite enamel • Removable oven door • Removable shelf runners • <hr/> <p>Controls</p> <ul style="list-style-type: none"> Adjustable audio and display settings • Audio feedback • Automatic cooking/minute timer • Automatic pre-set temperatures • Delay start • Electronic clock • Electronic oven control • Food probe • Guided cooking by food type and recipes • Internal Light • Intuitive touchscreen display • Multi-language display UK English Sabbath mode with Star K certification • Smart appliance • Soft close doors • True convection oven • Turned stainless steel dials with illuminated halos • <hr/> <p>Functions</p> <ul style="list-style-type: none"> Aero Broil • 	<ul style="list-style-type: none"> Aero™ Bake • Air fry • Bake • Broil • Defrost • Dehydrate • Fan forced + Micro (3 levels) • Fan grill + Micro (3 levels) • Grill + Micro (3 levels) • Maxi Broil • Number of functions 22 Pastry Bake • Pizza bake • Popcorn • Quick start • Rapid proof • Roast • Roast + Micro (3 levels) • Slow cook • True Aero • Vent bake • Warm • <hr/> <p>Performance</p> <ul style="list-style-type: none"> ActiveVent™ system • AeroTech™ technology • Automatic rapid pre-heat • Microwave by levels • Microwave power 900 W Microwave power levels 6 	<ul style="list-style-type: none"> Temperature range 95 °F - 445 °F <hr/> <p>Power Requirements</p> <ul style="list-style-type: none"> Amperage 23 A Supply frequency 60 Hz Supply voltage 208 - 240 V <hr/> <p>Product Dimensions</p> <ul style="list-style-type: none"> Depth 22 1/4 " Height 18 " Width 23 7/16 " <hr/> <p>Safety</p> <ul style="list-style-type: none"> ADA compliant • Balanced oven door • Control panel key lock • CoolTouch door • Non-tip shelves • Safety thermostat • <hr/> <p>SKU 82674</p> <hr/> <p>The product dimensions and specifications in this page apply to the specific product and model. Under our policy of continuous improvement, these dimensions and specifications may change at any time. You should therefore check with Fisher & Paykel's Customer Care Centre to ensure this page correctly describes the model currently available. © Fisher & Paykel Appliances Ltd 2020</p>
---	---	--

Other product downloads available at fisherpaykel.com

- [↓](#) DWG
- [↓](#) DXF
- [↓](#) Data Sheet (English)
- [↓](#) Installation Guide (English)
- [↓](#) Revit
- [↓](#) Rhino
- [↓](#) Right To Repair Declaration (English, Canadian French)
- [↓](#) SketchUp
- [↓](#) User Guide (English)
- [↓](#) User Guide (Canadian French)
- [↓](#) User Guide (Mexican Spanish)

Where applicable:

All appliances use energy, and energy usage typically generates carbon emissions. **Fisher & Paykel Appliances' In-use Energy Carbon Emissions Estimate** indicates carbon emissions from a product's in-use energy. This is calculated either annually or per cycle, using the product's market-specific energy label energy consumption data multiplied by the carbon emissions factor for energy in your country or region.

Our In-use Energy Carbon Emissions Estimate is designed to assist customers in making informed purchasing decisions when comparing different Fisher & Paykel products. For example, a heat pump dryer typically has a lower In-use Energy Carbon Emissions Estimate than a vented dryer.



A PEACE OF MIND SALE
24 Hours 7 Days a Week Customer Support
T 1.888.936.7872 W www.fisherpaykel.com