

24" Series 9 Minimal Compact Convection-Speed Oven

Series 9 | Minimal



The speed of microwave cooking with the versatility of convection oven technology in a compact companion model, for perfect pairing.

- Generous 1.7 cu ft capacity, with four shelf positions
- A Wired Temperature Sensor precisely monitors cooking in real time
- Guided touchscreen cooking makes it simple to navigate cooking processes

- Wi-Fi enabled and works with the SmartHQ™ app for remote control and notifications

DIMENSIONS

Height	18 "
Width	23 7/16 "
Depth	22 1/4 "

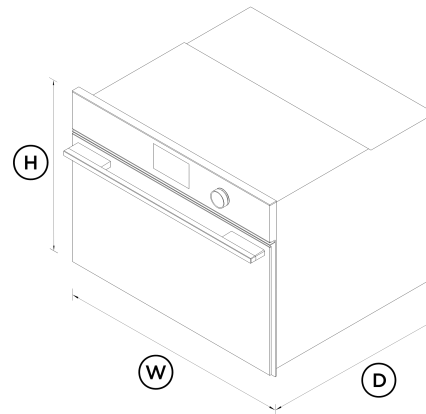

FEATURES & BENEFITS

Cooking Flexibility

Choose from 22 functions, including four microwave-only functions, 14 traditional oven functions, and four combination functions, giving you the best microwave and convection oven technology.

Cook With Confidence

The 5" screen provides an intuitive guided cooking experience that helps to deliver perfect results, whether you've been cooking all your life or are just starting out.

Sized To Suit

A compact 24" width means this microwave oven can be placed almost anywhere – all companion products can be installed at a convenient height to suit your kitchen design and preference.

Complementary Design

With a reflective black glass finish, this Minimal style oven is well-suited to a variety of kitchen designs. It's distinctive and timeless, whether on its own or part of a matching appliance set.

Multi-Function Flexibility

Each function has been tailored and tested to ensure perfect defrosting, heating and cooking.

Safe And Sound

The CoolTouch door is safe to touch from the outside, protecting your hands and the surrounding cabinetry.

SPECIFICATIONS

Accessories (included)

Chromed shelf runners	•
Glass tray	1
Step down wire shelf	1
Wire shelf	1
Wired temperature sensor	1

Capacity

Shelf positions	4
-----------------	---

Total capacity **1.7 cu ft**
 Usable capacity **1.3 cu ft**

Cleaning

- Acid resistant graphite enamel
- Removable oven door
- Removable shelf runners

Controls

- Automatic pre-set temperatures
- Dial with illuminated halo
- Electronic oven control
- Internal Light
- Intuitive touchscreen display
- Multi-language display **true**
- Sabbath mode with Star K certification
- Smart appliance
- Soft close doors

Functions

- Aero Broil
- Aero™ Bake
- Air fry
- Bake
- Broil
- Defrost
- Dehydrate
- Fan forced + Micro (3 levels)

- Fan grill + Micro (3 levels)
- Grill + Micro (3 levels)
- Maxi Broil
- Microwave cooking
- Pastry Bake
- Pizza bake
- Popcorn
- Quick start
- Rapid proof
- Roast
- Roast + Micro (3 levels)
- Slow cook
- True Aero
- Vent bake
- Warm

Performance

- ActiveVent™ system
- AeroTech™ technology
- Automatic rapid pre-heat
- Microwave by levels
- Microwave power **900 W**
- Microwave power levels **6**
- Temperature range **95 °F - 445 °F**

Power Requirements

- Amperage **23 A**
- Supply frequency **60 Hz**
- Supply voltage **208 - 240 V**

Product Dimensions

Depth **22 1/4 "**
 Height **18 "**
 Width **23 7/16 "**

SKU **82664**

The product dimensions and specifications in this page apply to the specific product and model. Under our policy of continuous improvement, these dimensions and specifications may change at any time. You should therefore check with Fisher & Paykel's Customer Care Centre to ensure this page correctly describes the model currently available. © Fisher & Paykel Appliances Ltd 2020

Other product downloads available at fisherpaykel.com

- [↓ 2D-DWG Convection Speed Oven](#)
- [↓ 2D-DXF Convection Speed Oven](#)
- [↓ Installation Guide EN](#)
- [↓ Planning Guide - 24" Ovens and Companions - Minimal EN](#)
- [↓ Revit](#)
- [↓ Rhino Convection Speed Oven](#)
- [↓ SketchUp Convection Speed Oven](#)
- [↓ User Guide EN](#)
- [↓ User Guide FR](#)
- [↓ User Guide SP](#)

Where applicable:

All appliances use energy, and energy usage typically generates carbon emissions. **Fisher & Paykel Appliances' In-use Energy Carbon Emissions Estimate** indicates carbon emissions from a product's in-use energy. This is calculated either annually or per cycle, using the product's market-specific energy label energy consumption data multiplied by the carbon emissions factor for energy in your country or region.

Our In-use Energy Carbon Emissions Estimate is designed to assist customers in making informed purchasing decisions when comparing different Fisher & Paykel products. For example, a heat pump dryer typically has a lower In-use Energy Carbon Emissions Estimate than a vented dryer.



A PEACE OF MIND SALE
24 Hours 7 Days a Week Customer Support
T 1.888.936.7872 W www.fisherpaykel.com