

# 24" Series 9 Contemporary Compact Combi-Steam Oven

Series 9 | Contemporary



Reduce the need for oils and fats with steam cooking. Its compact size makes this perfect to pair with a warming drawer underneath.

- 1.3 cu ft total capacity
- Cooking flexibility with nine oven functions, including five Steam functions, Broil and Convection
- Steam cooking allows you to cook a food in its own juices, to retain nutrients and flavour
- Designed to match aesthetically with companion products such as warming drawers, for flexible cooking configurations

## DIMENSIONS

Height	18 1/16 "
Width	23 7/16 "
Depth	22 1/8 "

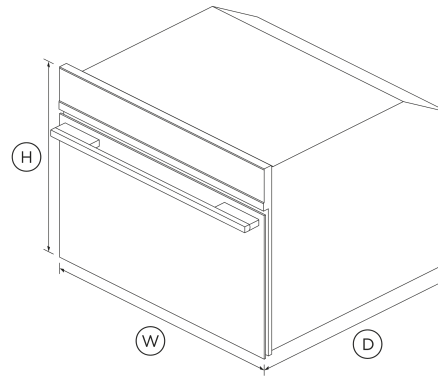

## FEATURES & BENEFITS

### SIZED TO SUIT

This compact 24" Steam Oven can be placed almost anywhere. All Companion products can be installed at a convenient height to suit your kitchen design and preference.

### SIMPLE TO USE

An easy to use, intuitive display shows the time and provides useful information about functions along with a refill alert.

### EASY CLEANING

Cleaning and care of the Steam Oven is simple. After each use, just wipe the smooth stainless steel interior with a dry cloth.

### SAFE & SOUND

The CoolTouch door is safe to touch from the outside, protecting your hands and the surrounding cabinetry.

### EASY INSTALLATION

Plug in and cook straight away. The Steam Oven is easy to install, with no plumbing needed.

### HEALTHY EATING

The Steam Oven allows you to cook food in its own juices to retain nutrients and flavor. With nine oven modes, it doesn't just steam, but also has Broil and Fan functions.

## SPECIFICATIONS

### Accessories (included)

Baking pan	1
Perforated large steam dish	1
Wire shelf	1
Wired temperature sensor	1

### Accessories (sold separately)

Optional lower trim kit	Part 81662
-------------------------	------------

### Capacity

Shelf positions	3
Total capacity	1.3 cu ft

### Cleaning

Easy clean stainless steel interior	•
-------------------------------------	---

- Removable water tank
- Steam clean (oven)

- Broil power **1500 W**
- SteamTechnology

**Controls**

- Audio feedback
- Automatic cooking/minute timer
- Celsius/Fahrenheit temperature
- Delay start
- Electronic clock
- Electronic oven control
- Food probe
- Guided cooking by food type and recipes
- Internal Light
- Intuitive touchscreen display

**Power Requirements**

- Amperage **15 A**
- Supply frequency **60 Hz**
- Supply voltage **208 - 240 V**

**Product Dimensions**

- Depth **22 1/8 "**
- Height **18 1/16 "**
- Width **23 7/16 "**

**Safety**

- ADA compliant
- Control panel key lock
- CoolTouch door
- Safety thermostat

SKU **82308**

The product dimensions and specifications in this page apply to the specific product and model. Under our policy of continuous improvement, these dimensions and specifications may change at any time. You should therefore check with Fisher & Paykel's Customer Care Centre to ensure this page correctly describes the model currently available. © Fisher & Paykel Appliances Ltd 2020

**Functions**

- Broil
- Convection Broil
- Number of functions **9**
- Recipe function
- Ring + broil
- Steam + ring
- Steam 100 (100°C / 210°F)
- Steam 130 (130°C / 265°F)
- Steam assist
- Steam clean (oven)

**Performance**

**Other product downloads available at fisherpaykel.com**

- [↓](#) DWG Appliance with 30" Trim
- [↓](#) DWG Appliance with Bottom Trim
- [↓](#) DWG
- [↓](#) DXF Appliance with 30" Trim
- [↓](#) DXF Appliance with Bottom Trim
- [↓](#) DXF
- [↓](#) Archicad
- [↓](#) Archicad Appliance with 24" Trim
- [↓](#) Archicad Appliance with 30" Trim
- [↓](#) Data Sheet Appliance with 30" Trim (English)
- [↓](#) Data Sheet Appliance with Bottom Trim (English)
- [↓](#) Data Sheet (English)
- [↓](#) Installation Guide (English)
- [↓](#) Installation Guide (Canadian French)
- [↓](#) Installation Guide - Cavity Trim Kit (English)
- [↓](#) Revit
- [↓](#) Revit Appliance with 24" Trim
- [↓](#) Revit Appliance with 30" Trim
- [↓](#) Rhino
- [↓](#) Rhino Appliance with 24" Trim
- [↓](#) Rhino Appliance with 30" Trim
- [↓](#) Right To Repair Declaration (English, Canadian French)
- [↓](#) SketchUp
- [↓](#) SketchUp Appliance with 24" Trim
- [↓](#) SketchUp Appliance with 30" Trim
- [↓](#) User Guide (English)

**Where applicable:**

All appliances use energy, and energy usage typically generates carbon emissions. **Fisher & Paykel Appliances' In-use Energy Carbon Emissions Estimate** indicates carbon emissions from a product's in-use energy. This is calculated either annually or per cycle, using the product's market-specific energy label energy consumption data multiplied by the carbon emissions factor for energy in your country or region.

Our In-use Energy Carbon Emissions Estimate is designed to assist customers in making informed purchasing decisions when comparing different Fisher & Paykel products. For example, a heat pump dryer typically has a lower In-use Energy Carbon Emissions Estimate than a vented dryer.



**A PEACE OF MIND SALE**  
24 Hours 7 Days a Week Customer Support  
T 1.888.936.7872 W [www.fisherpaykel.com](http://www.fisherpaykel.com)