

# Series 7, Integrated Tall Dishwasher

Series 7 | Integrated



Designed to be integrated seamlessly into your cabinetry, this dishwasher delivers extra wash options and Auto Door Open Dry.

- Customize with your own front panel and handle to match your kitchen cabinetry
- Seven wash programs from Heavy to Light, including Auto and 60min
- Dry+, Sanitize and Half Load modifiers provide extra wash options
- Wi-Fi enabled and works with the SmartHQ™ app for remote control and notifications

## DIMENSIONS

Height	33 3/4 - 36 1/8 "
Width	23 1/2 "
Depth	21 13/16 "

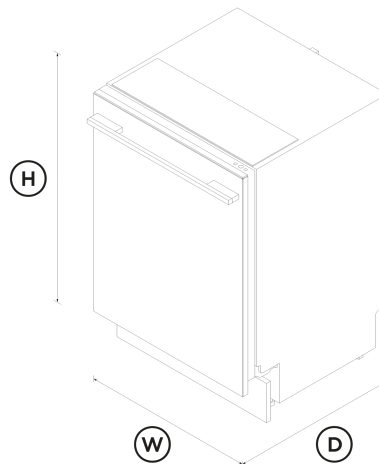

## FEATURES & BENEFITS

### Seamless Integration

Customize your dishwasher with a panel and handle matching your cabinetry, for a seamless finish in your kitchen.

### Effortless Drying

For beautifully dry dishes every time, this dishwasher features the Auto Door Open Dry function. This function automatically releases excess steam at the end of the cycle, ensuring dishes are immediately ready for use or storage. An innovative air curtain channels the steam away from the adjacent benchtop, protecting your cabinetry.

### A Reliable Clean

This dishwasher offers seven wash programs including Auto, which automatically senses the optimal wash settings for your dishes. The three-stage filtration system delivers a superior clean, while the rinse aid indicator reminds you to top up for beautifully clean dishes.

### Customize Your Wash

The Half Load modifier is perfect for washing a partial load, for faster turnaround of dishes. Sanitize provides extra protection, killing 99.9% of bacteria\* in the final rinse, while the Dry+ modifier is great for plastic dishes.

\*Certified to NSF/ANSI Standard 184

### Efficient Performance

With an Energy Star Most Efficient rating, this dishwasher is recognised as among the most energy efficient models on the market. Use the Eco wash program for optimal water and energy consumption, or choose when the cycle begins with Delay Start.

### Flexible Loading

Designed to fit 15 place settings with ease, adjustable racks help you to load and care for various items - including a height-adjustable upper basket, and foldable cup holders and tines.

## SPECIFICATIONS

### Accessories (included)

Kickstrip true

### Accessories (sold separately)

Door panel stainless steel ADDW24TPX  
 Handle kit Classic AHCL-DDDW-24X

Handle kit Contemporary round, aluminium	<b>AHS-OBDD-60S</b>
Handle kit Contemporary square fine, aluminium	<b>AHD5-OBDD-60SX</b>
Handle kit Contemporary square fine, black	<b>AHD5-OBDD-60SB</b>
Handle kit Professional round flush	<b>AHP3-DWDD-SX</b>
Handle kit Professional round flush, Brass off-stands	<b>AHP3DDD24BA</b>
Handle kit Professional round flush, Dark Copper off-stands	<b>AHP3DDD24DC</b>

**Capacity and loading**

Accommodates round plates up to (lower basket)	<b>12 3/4"</b>
Accommodates round plates up to (top basket)	<b>9 13/16"</b>
Adjustable height, foldable cupracks	•
Easy lift adjustable upper basket	•
Fold down tines	•
Fold down wine racks	•
Place settings	<b>15</b>
Place settings	<b>15</b>

**Consumption**

Energy rating	<b>Energy star Most efficient</b>
Energy usage	<b>224kWh/year</b>
In-use energy carbon emissions estimate	<b>79.0kgCO2e/year</b>
Water usage (per wash cycle)	<b>3.2 gal</b>

**Controls**

Energy saving delay start option of up to 12 hours	•
Internal wash selector	•
Keylock	•
Rinse aid indicator light	•
Smart appliance	•

**Features**

Air curtain for bench protection	•
Auto Door Open Dry	•
Flood protection	•
Half load option	•
Internal tub material	<b>Stainless Steel</b>
Motor type	<b>Asynchronous</b>
ThermoDry system	•
Three-stage filtration system	•

**Performance**

Noise emissions	<b>46 dBA</b>
-----------------	---------------

**Power Requirements**

Amperage	<b>10A</b>
Supply frequency	<b>60Hz</b>
Supply voltage	<b>100 - 120V</b>

**Product Dimensions**

Depth	<b>21 13/16 "</b>
Height	<b>33 3/4 - 36 1/8 "</b>

Width	<b>23 1/2 "</b>
-------	-----------------

**Wash Program Modifiers**

Dry +	•
Half load	•
Sanitise	•
Wash modifiers	<b>3</b>

**Wash Programs**

60 min	•
Auto	•
Eco	•
Heavy	•
Light	•
Medium	•
Rinse	•
Wash programs	<b>7</b>

**Water connection**

Water pressure	<b>30kPa - 1000 kPa</b>
----------------	-------------------------

SKU	<b>82443</b>
-----	--------------

The product dimensions and specifications in this page apply to the specific product and model. Under our policy of continuous improvement, these dimensions and specifications may change at any time. You should therefore check with Fisher & Paykel's Customer Care Centre to ensure this page correctly describes the model currently available. © Fisher & Paykel Appliances Ltd 2020



**A PEACE OF MIND SALE**  
**24 Hours 7 Days a Week Customer Support**  
T 1.888.936.7872 W [www.fisherpaykel.com](http://www.fisherpaykel.com)

#### Other product downloads available at [fisherpaykel.com](http://fisherpaykel.com)

- [↓](#) 2D-DWG Integrated Dishwasher
- [↓](#) 2D-DXF Integrated Dishwasher
- [↓](#) Data Sheet Integrated Dishwasher
- [↓](#) Energy Label Dishwasher
- [↓](#) Installation Guide EN
- [↓](#) Guide d'installation FR
- [↓](#) Planning Guide Professional Style Dial/Handle Accessories
- [↓](#) Right To Repair Declaration (English, Canadian French)
- [↓](#) User Guide (English, Canadian French)

#### Where applicable:

All appliances use energy, and energy usage typically generates carbon emissions. **Fisher & Paykel Appliances' In-use Energy Carbon Emissions Estimate** indicates carbon emissions from a product's in-use energy. This is calculated either annually or per cycle, using the product's market-specific energy label energy consumption data multiplied by the carbon emissions factor for energy in your country or region.

Our In-use Energy Carbon Emissions Estimate is designed to assist customers in making informed purchasing decisions when comparing different Fisher & Paykel products. For example, a heat pump dryer typically has a lower In-use Energy Carbon Emissions Estimate than a vented dryer.