

17.1 cu ft Series 5 Refrigerator Freezer, Ice

Width 31 1/8 "
Depth 27 3/8 "

Your fruit and veges need different environments to stay fresh. Humidity control in each storage bin allows you to maintain a microclimate that helps keep food fresher for longer.

Series 5 | Contemporary



This stylish left hinge refrigerator is designed to fit flush with your cabinetry and comes in timeless stainless steel.

- ActiveSmart™ Foodcare technology helps keep food fresher for longer
- Flat door that fits flush with cabinetry
- Brushed metal handles

DIMENSIONS

Height 67 3/4 "

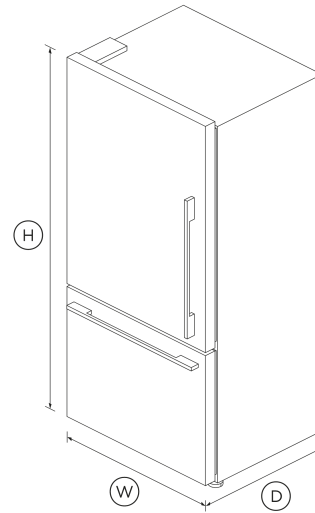

FEATURES & BENEFITS

Activesmart™ Foodcare

This refrigerator freezer adapts to daily use by cooling and defrosting only when needed. ActiveSmart™ Foodcare technology uses energy efficiently without compromising on food care.

Flexible Storage

Adjustable shelves and door storage give you plenty of room to stack and pack all your groceries. Storage bins give you full access inside when they're pulled open and can be easily removed to clean.

Humidity Control

Design Quality

Our fridges are designed and built using quality materials. We use real stainless steel on our fridges and solid glass for shelving.

Internal Ice Maker

Fresh ice is always available for you in a dedicated freezer bin. Simply turn it off to free up freezer space or during busy times, you can boost ice production by up to 30%.

Easy Cleaning

No more stubborn dirty marks with our EZKleen feature for stainless steel fridges. Anti-fingerprint coating means you simply wipe clean any marks. Spill-safe secure glass shelves easily capture any drips or leaks.

Easy to use

The SmartTouch control panel has been designed to be intuitive for ease to use, and is conveniently placed near the front of the fridge.

SPECIFICATIONS

Accessories (sold separately)

Joiner Kit	819264
Surround Kit (Joined left/right pair)	Part number 24476
Water filter replacement	847200 - FWC3

Capacity

Total gross capacity	17.1 cu ft
Volume freezer	4.8 cu ft

Volume refrigerator **12.3 cu ft**

Consumption

Energy rating **Energy Star**
 Energy usage **535kWh/year**
 In-use energy carbon emissions estimate **188.7kgCO2e/year**

Features

Adjustable door shelves **14**
 Adjustable glass shelves **4**
 Covered door shelves **2**
 Door alarm •
 Front levelling feet •
 Fruit and vegetable bins **2**
 LED lighting •
 Rear rollers •
 Smart appliance •
 SmartTouch control panel •
 Stackable bottle holders **4**

Freezer Features

Automatic ice maker •
 Bottle chill •
 Door alarm •
 Fast freeze •
 Ice bin and scoop •
 Ice Boost •
 Large plastic bins •

Performance

ActiveSmart™ Foodcare •
 Adaptive defrost •
 Frost Free Freezer •
 Humidity control system •
 Inverter controlled compressor •
 Sabbath mode •

Power Requirements

Rated current **10 A**
 Supply frequency **60 Hz**
 Supply voltage **110 - 120 V**

Product Dimensions

Depth **27 3/8 "**
 Height **67 3/4 "**
 Width **31 1/8 "**

SKU **26293**

The product dimensions and specifications in this page apply to the specific product and model. Under our policy of continuous improvement, these dimensions and specifications may change at any time. You should therefore check with Fisher & Paykel's Customer Care Centre to ensure this page correctly describes the model currently available. © Fisher & Paykel Appliances Ltd 2020

Other product downloads available at fisherpaykel.com

- [↓ Energy Label](#)
- [↓ Water Filter Replacement Instructions - Parts 847200 and 847201 \(English\)](#)
- [↓ Water Filter Replacement Instructions - Parts 862285 and 862288 \(English\)](#)
- [↓ Installation Guide - Joiner Kit EN](#)
- [↓ Installation Guide EN](#)
- [↓ Water Filter Replacement Instructions - Parts 847200 and 847201 - FR](#)
- [↓ Water Filter Replacement Instructions - Parts 862285 and 862288 - FR](#)
- [↓ Installation Guide - Joiner Kit FR](#)
- [↓ Installation Guide FR](#)
- [↓ Right To Repair Declaration \(English, Canadian French\)](#)
- [↓ User Guide Refrigerator Freezer EN](#)
- [↓ User Guide Refrigerator Freezer FR](#)

Where applicable:

All appliances use energy, and energy usage typically generates carbon emissions. **Fisher & Paykel Appliances' In-use Energy Carbon Emissions Estimate** indicates carbon emissions from a product's in-use energy. This is calculated either annually or per cycle, using the product's market-specific energy label energy consumption data multiplied by the carbon emissions factor for energy in your country or region.

Our In-use Energy Carbon Emissions Estimate is designed to assist customers in making informed purchasing decisions when comparing different Fisher & Paykel products. For example, a heat pump dryer typically has a lower In-use Energy Carbon Emissions Estimate than a vented dryer.



A PEACE OF MIND SALE
24 Hours 7 Days a Week Customer Support
 T 1.888.936.7872 [Wwww.fisherpaykel.com](http://www.fisherpaykel.com)