

30" Series 7 Professional Self-Cleaning Oven, 10 Function

Professional



A highlight of the Fisher & Paykel range, this Series 7 oven ensures that every dish you create is cooked to perfection.

- 4.1 cu ft total capacity
- 10 oven functions including Aero™ Pastry and Roast
- High-temperature self-cleaning function breaks down food residue for an easy clean
- Non-tip, full-extension shelves for safe removal of hot dishes

DIMENSIONS

Height	27 1/8 "
Width	29 3/4 "
Depth	23 15/16 "

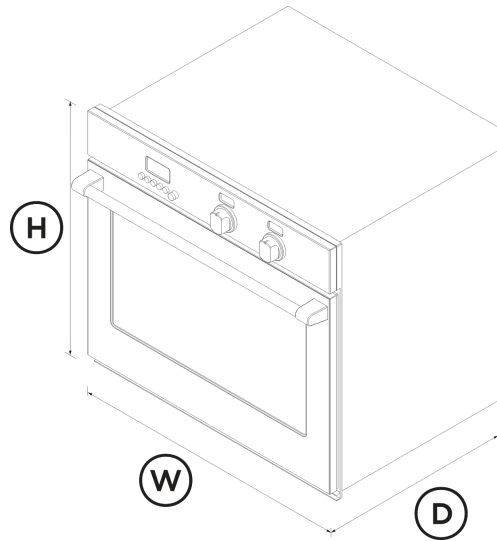

SPECIFICATIONS

Accessories (included)

Full extension sliding shelves	3 sets
Wired temperature sensor	1

Capacity

Shelf positions	8
Total capacity	4.1 cu ft
Usable capacity	3.6 cu ft

Cleaning

- Acid resistant graphite enamel
- Pyrolytic self-clean
- Removable oven door
- Removable side ladders

Controls

- Automatic cooking/minute timer
- Automatic pre-set temperatures
- Celsius/Fahrenheit temperature
- Delay start
- Electronic clock
- Electronic oven control
- Internal Light
- LED display
- True convection oven
- Turned stainless steel dials with illuminated halos

Functions

- Bake
- Broil
- Convection bake
- Convection Broil
- Convection pastry
- Maxi Broil
- Number of functions **10**
- Pastry Bake
- Pyrolytic self-clean
- Roast

True convection	•
Warm	•

SKU 82947



A PEACE OF MIND SALE
 24 Hours 7 Days a Week Customer Support
 T 1.888.936.7872 W www.fisherpaykel.com

Performance

AeroTech™ technology	•
Automatic rapid pre-heat	•
Broil power	4400 W
Broil width	20 "

The product dimensions and specifications in this page apply to the specific product and model. Under our policy of continuous improvement, these dimensions and specifications may change at any time. You should therefore check with Fisher & Paykel's Customer Care Centre to ensure this page correctly describes the model currently available. © Fisher & Paykel Appliances Ltd 2020

Other product downloads available at fisherpaykel.com

- [↓](#) Installation Guide (English, Canadian French)
- [↓](#) Quick Start Guide (English)
- [↓](#) Quick Start Guide (Canadian French)
- [↓](#) Right To Repair Declaration (English, Canadian French)
- [↓](#) User Guide (English)

Power Requirements

Amperage	30 A
Rated current	30 A
Supply frequency	60 Hz
Supply voltage	208 - 240 V

Where applicable:

All appliances use energy, and energy usage typically generates carbon emissions. **Fisher & Paykel Appliances' In-use Energy Carbon Emissions Estimate** indicates carbon emissions from a product's in-use energy. This is calculated either annually or per cycle, using the product's market-specific energy label energy consumption data multiplied by the carbon emissions factor for energy in your country or region.

Our In-use Energy Carbon Emissions Estimate is designed to assist customers in making informed purchasing decisions when comparing different Fisher & Paykel products. For example, a heat pump dryer typically has a lower In-use Energy Carbon Emissions Estimate than a vented dryer.

Product Dimensions

Depth	23 15/16 "
Height	27 1/8 "
Width	29 3/4 "

Safety

ADA compliant	•
Control panel key lock	•
CoolTouch door	•
Non-tip shelves	•
Safety thermostat	•