

# 20.1 cu ft Series 7 French Door Refrigerator Freezer

**Width** 35 7/16 "  
**Depth** 27 3/8 "

### Complementary Design

With their premium handle styling and stainless steel finish, our refrigerators are designed to match the rest of Fisher & Paykel's kitchen appliance family.

### Humidity Control

Your fruit and veges need different environments. The humidity control slides in each storage bin create a microclimate that helps keep food fresher for longer.

### SPECIFICATIONS

#### Capacity

Total gross capacity	<b>20.1 L</b>
Total gross capacity	<b>20.1 cu ft</b>
Volume freezer	<b>5.5 cu ft</b>
Volume refrigerator	<b>14.6 cu ft</b>

#### Consumption

Energy rating	<b>Energy Star</b>
Energy usage	<b>448kWh/year</b>
In-use energy carbon emissions estimate	<b>158.0kgCO2e/year</b>

#### Features

Adjustable door shelves	<b>8</b>
Adjustable glass shelves	<b>3</b>
Covered door shelves	<b>2</b>
Deli storage bins	<b>2</b>
Door alarm	<b>•</b>
Fruit and vegetable bins	<b>2</b>
Full width door shelves	<b>2</b>

Contemporary



Designed for those who need plenty of flexible space for their cold and frozen food storage, with a stylish stainless steel finish.

- ActiveSmart™ helps keep food fresher for longer
- Bottom freezer drawer
- Brushed metal handles

### DIMENSIONS

**Height** 70 3/4 "

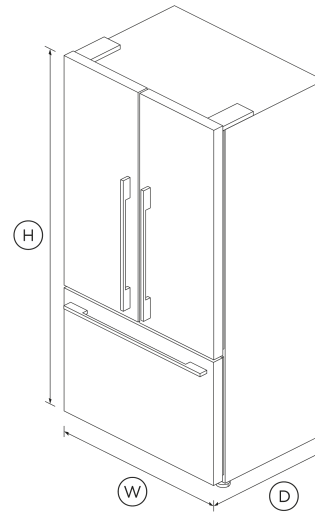

### FEATURES & BENEFITS

#### ActiveSmart™ Foodcare

ActiveSmart™ Foodcare learns how you live. It's technology which understands how you use your refrigerator and adjusts temperature, airflow and humidity inside to help keep food fresher for longer.

#### Easy Cleaning

Spill-safe secure glass shelves easily capture any drips or leaks and prevent them from falling on items below.

#### Design Quality

Our refrigerators are designed and built using quality materials. We use real stainless steel on our refrigerators and solid glass for shelving.

LED lighting	•
Smart appliance	•
SmartTouch control panel	•
Stackable bottle holders	4

Width **35 7/16 "**

SKU 26310

The product dimensions and specifications in this page apply to the specific product and model. Under our policy of continuous improvement, these dimensions and specifications may change at any time. You should therefore check with Fisher & Paykel's Customer Care Centre to ensure this page correctly describes the model currently available. © Fisher & Paykel Appliances Ltd 2020

All appliances use energy, and energy usage typically generates carbon emissions. **Fisher & Paykel Appliances' In-use Energy Carbon Emissions Estimate** indicates carbon emissions from a product's in-use energy. This is calculated either annually or per cycle, using the product's market-specific energy label energy consumption data multiplied by the carbon emissions factor for energy in your country or region.

Our In-use Energy Carbon Emissions Estimate is designed to assist customers in making informed purchasing decisions when comparing different Fisher & Paykel products. For example, a heat pump dryer typically has a lower In-use Energy Carbon Emissions Estimate than a vented dryer.

**Freezer Features**

Bottle chill	•
Fast freeze	•
Ice trays	1

**Performance**

ActiveSmart™ Foodcare	•
Adaptive defrost	•
Frost Free Freezer	•
Humidity control system	•
Sabbath mode	•

**Other product downloads available at fisherpaykel.com**

- [↓](#) DWG
- [↓](#) DXF
- [↓](#) Archicad
- [↓](#) Data Sheet (English)
- [↓](#) Energy Label
- [↓](#) Installation Guide (English)
- [↓](#) Installation Guide (English)
- [↓](#) Water Filter Replacement Instructions - Parts 847200 and 847201 (French)
- [↓](#) Installation Guide (Canadian French)
- [↓](#) Revit
- [↓](#) Rhino
- [↓](#) Right To Repair Declaration (English, Canadian French)
- [↓](#) SketchUp
- [↓](#) User Guide (English)
- [↓](#) User Guide (Canadian French)

Where applicable:

**Power Requirements**

Rated current	<b>10 A</b>
Supply frequency	<b>60 Hz</b>
Supply voltage	<b>115 V</b>

**Product Dimensions**

Depth	<b>27 3/8 "</b>
Height	<b>70 3/4 "</b>
Minimum air clearance at rear	<b>1 3/16 "</b>
Minimum air clearance each side	<b>13/16 "</b>



**A PEACE OF MIND SALE**  
**24 Hours 7 Days a Week Customer Support**  
 T 1.888.936.7872 Wwww.fisherpaykel.com