

NOTES:

1. TO INSPECT ASSEMBLY, FOLLOW FIRST ARTICLE AND IN PROCESS INSPECTION SHEET.

2 APPLY LOCTITE 680 TO THREADS

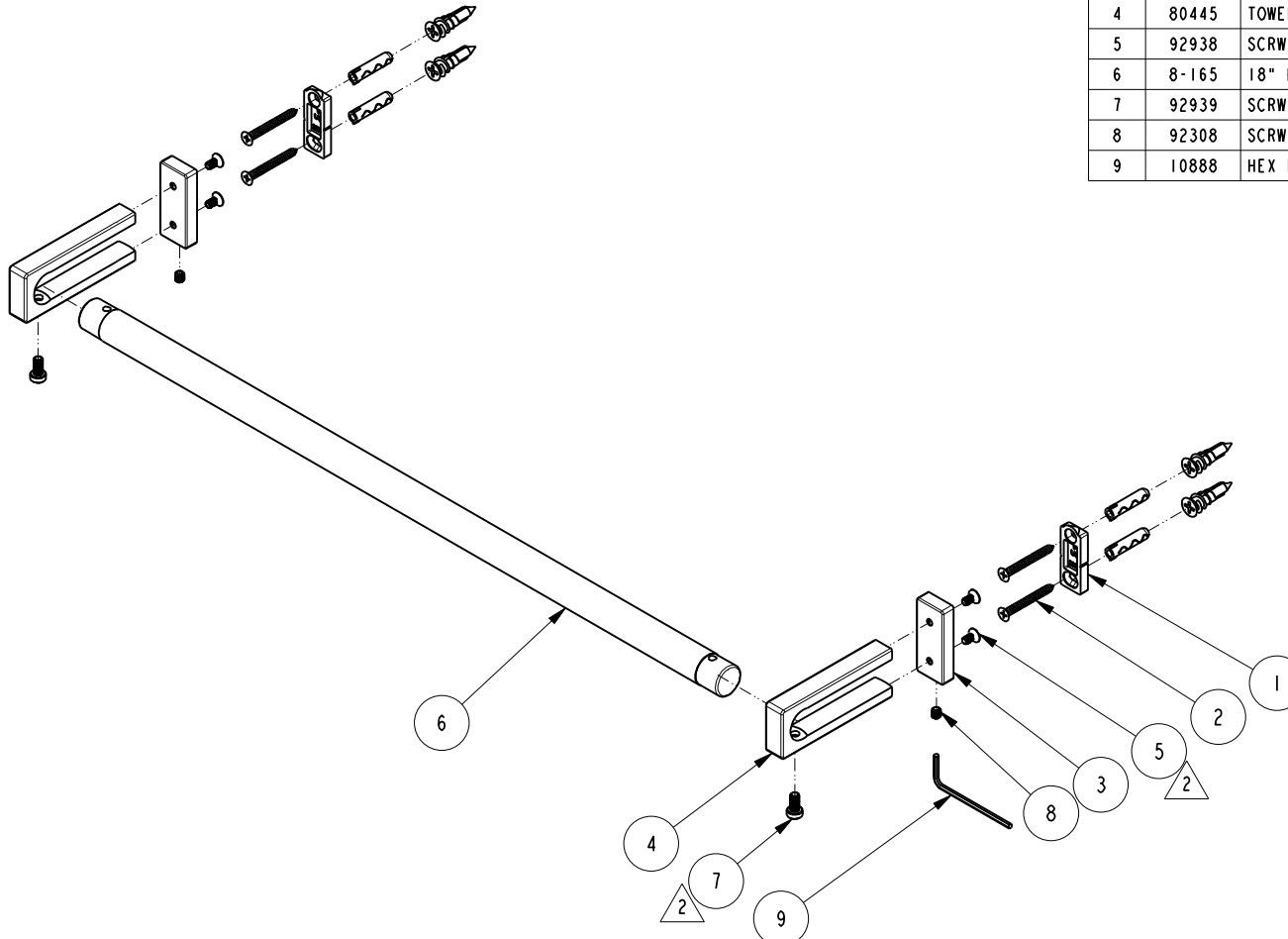

BILL OF MATERIAL (CURRENT LEVEL)

ITEM	PT/ASSY	DESCRIPTION	TYPE	QTY.
1	30XX	MOUNTING BRACKET - SHORT	PART	2
2	1-206	HARDWARE PACK	ASSEMBLY	2
3	80775	BACKPLATE	PART	2
4	80445	TOWEL BAR AND TOILET TISSUE HOLDER POST	PART	2
5	92938	SCRW, M4 X .7 X 8 SKT FLT HD SS	PART	4
6	8-165	18" BAR	ASSEMBLY	1
7	92939	SCRW, M5 X .8 X 10 SKT LOW PROFILE CAP HD SS	PART	2
8	92308	SCRW, M5 X 5 SKT HD CUP PT W/ SELF LOC SS	PART	2
9	10888	HEX KEY, 2.5MM ALLOY STEEL	PART	1

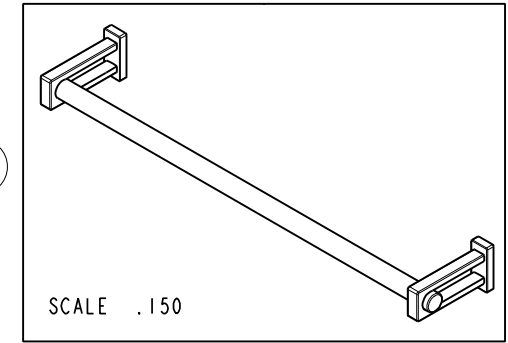

COPYRIGHT 2005 BRASSTECH, INC. THESE DRAWINGS AND THE DESIGNS DEPICTED HEREIN ARE THE PROPRIETARY PROPERTY OF BRASSTECH. ANY USE OR REPRODUCTION IS SUBJECT TO THE EXPRESS APPROVAL OF BRASSTECH. UNAUTHORIZED USE IS STRICTLY PROHIBITED. ALL RIGHTS RESERVED.

TESTING	-	-	-
ASSEMBLY	-	-	-
PLATING	-	-	-
POLISHING	-	NEXT ASSY	USED ON
MACHINING	-	APPLICATION	
TOOLING FIXTURE #	REMOVE ALL BURRS AND SHARP EDGES		

UNITS ARE: INCHES [MM]		
TOLERANCES ARE:		
FRACTIONS	DECIMALS	ANGLES
±1/16"	.X ±.1 [2.5]	±°
	.XX ±.06 [1.5]	
(X.XXX) DENOTES CRITICAL DIMS.		
ALL THREADS ARE CRITICAL		
DRAWN	JINSON	11/16/21
CHECKED	R.S.	11/16/21
APPROVED	R.S.	11/16/21

**BRASSTECH** 2001 CARNEGIE AVE. SANTA ANA, CA 92705 (949) 417-5207  
INCORPORATED

18" TOWEL BAR

DWG NO. 3002 REV C

SCALE .250 REF. - SHEET 1 OF 2

ZONE	REV	DESCRIPTION	DATE	APPROVED
-	C	EN-4417	11/16/21	R.S.

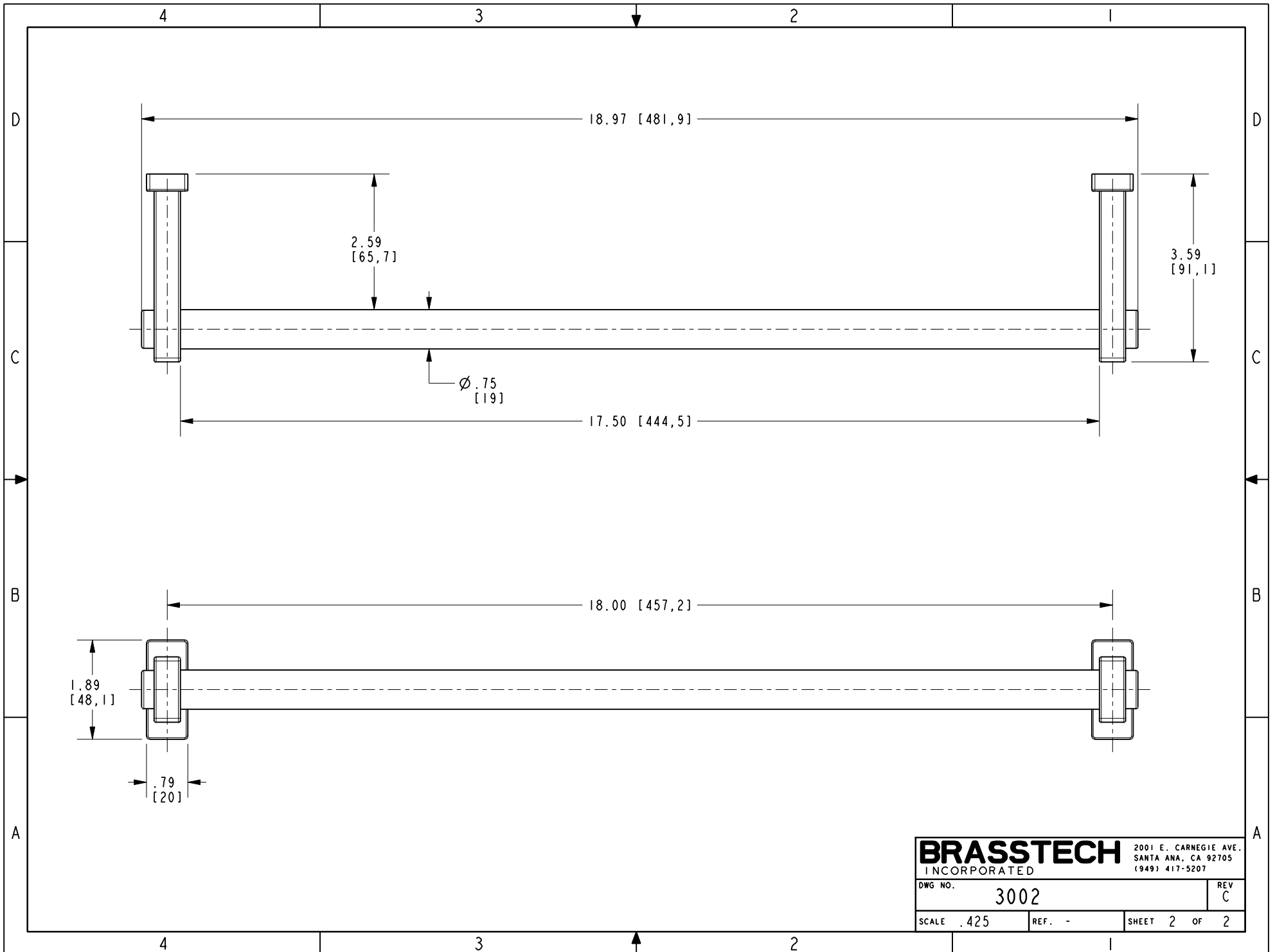

<b>BRASSTECH</b>		2001 E. CARNEGIE AVE. SANTA ANA, CA 92705 (949) 417-5207	
DWG NO.	3002	REV	C
SCALE	.425	REF.	-
SHEET 2		OF 2	